

Slam Specialties

Model No. : MC.1-SS

Made in USA

Control Systems

The MC.1 is a two part control system for air suspension vehicles consisting of a handheld control unit and the accompanying receiver/driver module. Microprocessors and solid state drivers offer fast, reliable response while communicating with each other over a single wire, making the unit easy to install and flexible to move.

There are two multi-conductor cables in the receiver box. The 3-conductor is for power, ground and ignition; the 9-conductor is for hooking up your valves. Please follow these instructions for wiring your MC.1.

WARNING DO NOT mount the receiver in an area that could be exposed to moisture - The receiver is not water tight and can be damaged if wet

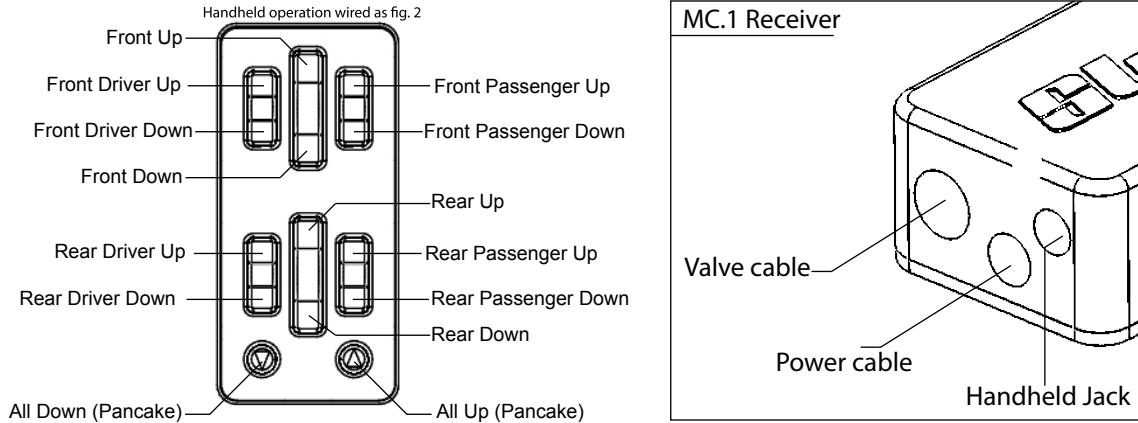

The MC.1 can be wired in multiple configurations depending on the desired orientation of the handheld (fig. 2 and fig. 3). below is the valve wiring diagram for each configuration. Connect the power wire as per fig 1. for **BOTH** configurations.

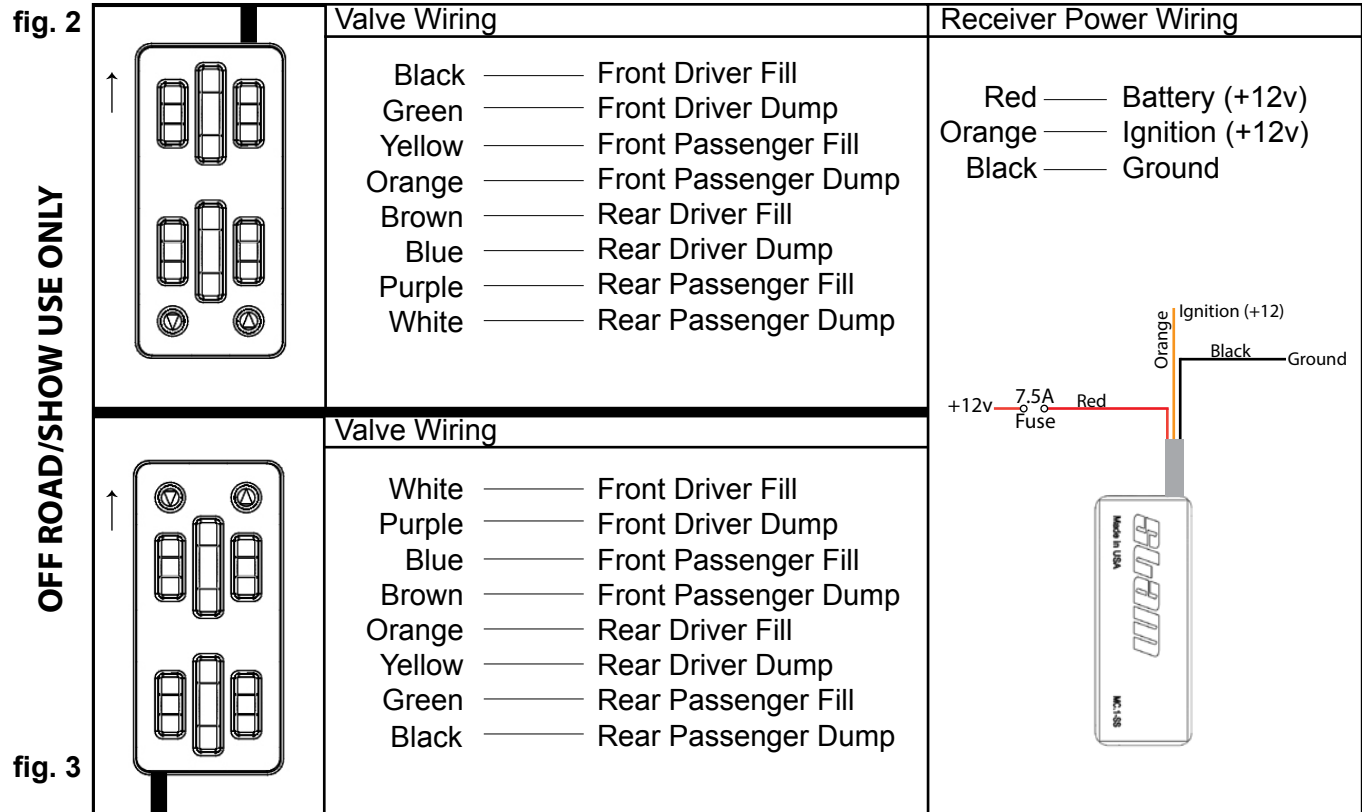

Thank you for purchasing the MC.1 Controller from Slam Specialties. This page includes installation instructions as well as contact information for technical support. If you have any questions about the operation of this unit, please call 888-352-5225.

SLAM SPECIALTIES

Model No. : MC.1-SS

Made in USA

Control Systems

Contents:

- (1) Handheld Unit
- (1) Receiver Unit
- (8) Male Bullet Connectors
- (1) 7.5A ATC fuse
- (2) Self tapping screws

Dimensional Data:

WARNING DO NOT mount the receiver in an area that could be exposed to moisture - The receiver is not water tight and can be damaged if wet

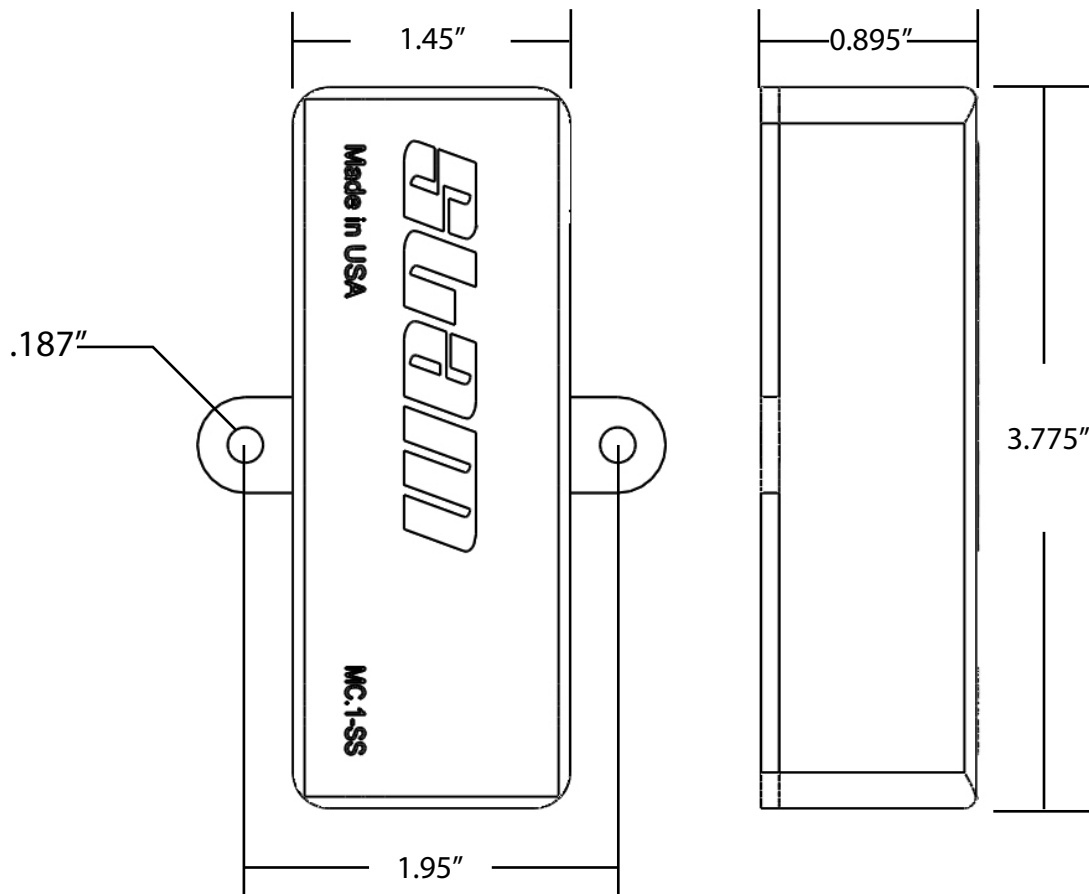

OFF-ROAD/SHOW USE ONLY

SLAM SPECIALTIES

Model No. : MC.1-SS

Made in USA

Control Systems

Dimensional Data:

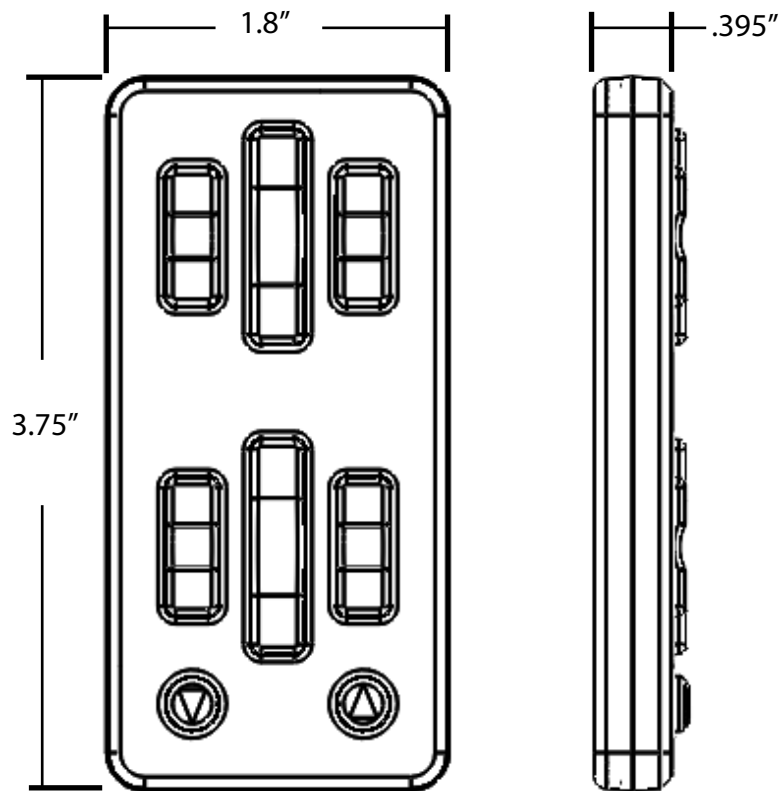

OFF-ROAD/SHOW USE ONLY