

SLAM SPECIALTIES

Model No. : 201010

Made in USA

MC.1-SS Control System

The MC.1 is a two part control system for air suspension vehicles consisting of a handheld control unit and the accompanying receiver/driver module. Microprocessors and solid statedrivers offer fast, reliable response while communicating with each other over a single wire, making the unit easy to install and flexible to move.

There are (2) multi-conductor cables and (4) individual wires in the receiver harness. The 8 conductor cable is the output to the valve, the other cable is a USB-C cable for the hand-unit. Please follow these instructions for wiring your MC.1

WARNING DO NOT mount the receiver in the area that could be exposed to moisture - The receiver is not water tight and can be damaged if wet

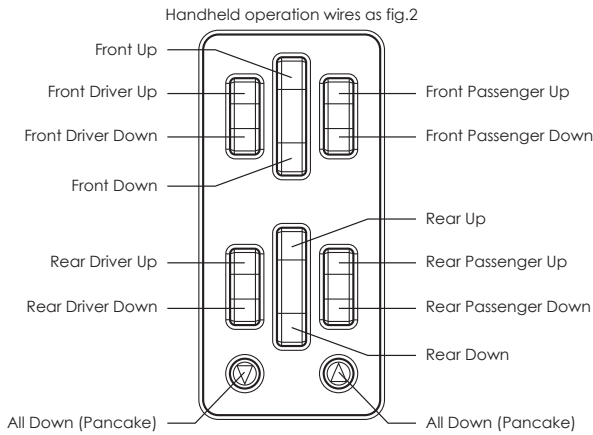

Product Contents:

- (1) Hand Unit
- (1) Receiver Unit
- (1) Receiver Harness
- (1) Mounting Clip
- (1) 1 Amp ATC fuse (spare)
- (1) 10 Amp ATC fuse (spare)
- (1) 1/4" Blue ring terminal
- (2) Self tapping mounting screws
- (3) Blue Quick Splcce
- (8) Female Bullet connectors
- (8) Male Bullet connectors

Wiring			Receiver Power Wires
Port	Function	Wire Color	
1	Fill	Black	
	Exhaust	Green	
2	Fill	Yellow	
	Exhaust	Orange	
3	Fill	Brown	
	Exhaust	Blue	
4	Fill	Purple	
	Exhaust	White	

Receiver Wiring

Red - Ignition (+12V)
Yellow - Battery (+12V)
Black - Ground
Orange - Not used

OFF ROAD/SHOW USE ONLY

Thank you for purchasing the MC.1 Controller from Slam Specialties. This page includes installation instructions as well as contact information for technical support. If you have any questions about the operation of this unit, please call 888-352-5225.

SLAM SPECIALTIES

Model No. : 201010

Made in USA

MC.1-SS Control System

Dimensional Data:

Receiver: 3" x 1.437" x 0.75"

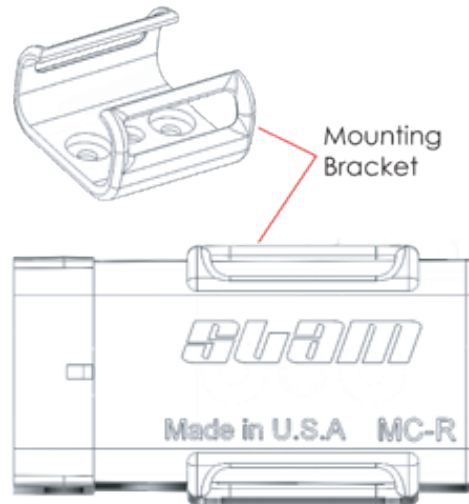

WARNING DO NOT mount the receiver in the area that could be exposed to moisture - The receiver is not water tight and can be damaged if wet

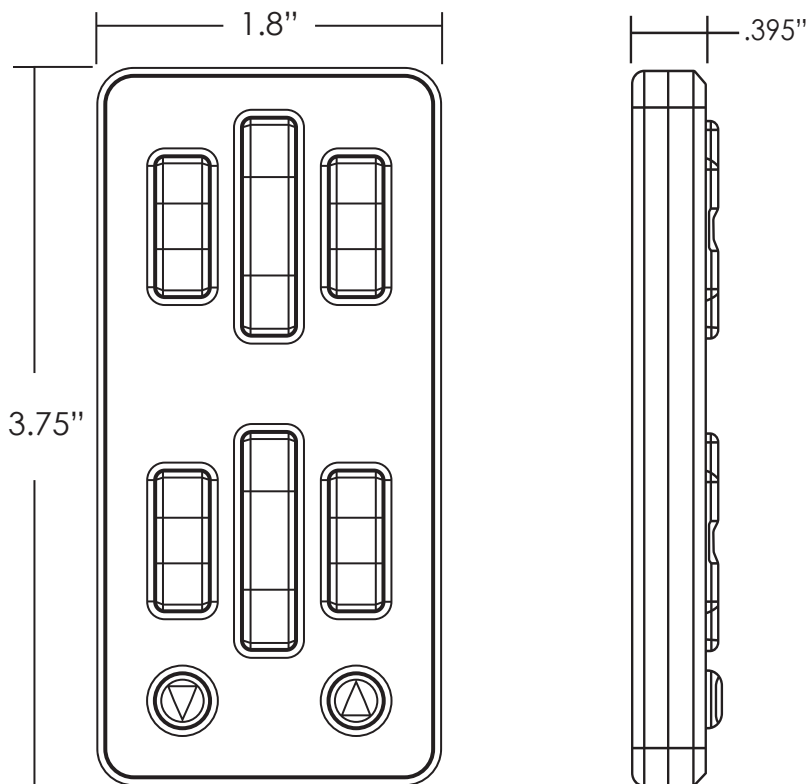

OFF ROAD/SHOW USE ONLY